



**GUIDELINE FOR
INSULATING METAL BUILDINGS
WITH
SPRAY APPLIED POLYURETHANE FOAM**

Spray Polyurethane Foam Alliance
4400 Fair Lakes Court, Suite 105
Fairfax, VA 22033
Copyright 2000

To order a copy of this publication, call 800-523-6154 and request Stock Number AY-134.

TECHNICAL COMMITTEE

MISSION STATEMENT

The mission of the Technical Committee is to provide a wide range of technical service to the Spray Polyurethane Foam industry such as, but not limited to:

1. Review existing documents and serve as a clearing house to ensure the “Continuity of Value” of technical information published by SPFA and others concerning the products and services to the SPF industry;
2. Review, research, develop and issue documents concerning new products, systems and services AND
3. To identify, explore, develop and communicate an understanding of technical issues facing to the SPF industry.

TECHNICAL COMMITTEE MEMBERS

Bill Jackson, Chairman
Mainland Industrial Coatings, Inc.

Bruce Schenke
BASF

Brad Beauchamp
Stepan Co.

Frank Sica
Gusmer Corporation

Mary Bogdan
Honeywell

Larry Smiley
Polydyne, Inc.

Beau Burris
Roofmart International Inc.

Robert Smith
KoSa

John P. Courier
Equipment & Coatings Technology

John Stahl
Preferred Solutions

Lionel Hotstream
Lundin Roofing Company, Inc.

Dennis Vandewater
Sadler Construction Inc.

Tim Leonard
ERSystems

AD HOC MEMBER

Roger Morrison
North Carolina Foam Industries

John Hatfield
Penta Engineering

This brochure was developed to aid specifiers in choosing spray polyurethane foam systems. The information provided herein, based on current customs and practices of the trade, is offered in good faith and believed to be accurate, but is made WITHOUT WARRANTY, EITHER EXPRESS OR IMPLIED, AS TO FITNESS, MERCHANTABILITY, OR ANY OTHER MATTER. SPFA DISCLAIMS ALL LIABILITY FOR ANY LOSS OR DAMAGE ARISING OUT OF ITS USE. Individual manufacturers and contractors should be consulted for specific information. Nominal values that may be provided herein are believed to be representative, but are not to be used as specifications nor assumed to be identical to finished products. SPFA does not endorse the products or processes of any individual manufacturer, or the services of any individual contractor.

TABLE OF CONTENTS

DESIGN CONSIDERATIONS

General Considerations	4
Determining Insulation Thickness.....	4
Surface Preparation	4
Selection of Primer	4
Selection of a Vapor Retarder	4
Selection of the Spray Polyurethane Foam System.....	5
Selection of a Protective Coating System	5
Selection of a Thermal Barrier	6
Metal Building Decision Flow Chart	6

RECOMMENDED GUIDE SPECIFICATION FOR INSULATING METAL BUILDINGS

PART 1 - GENERAL

1.01	Scope of Work	7
1.02	Related Work Specified Elsewhere.....	7
1.03	Quality Assurance	7
1.04	Submittals.....	7
1.05	Materials Delivery and Storage.....	7
1.06	Environmental Conditions	8
1.07	Sequence and Scheduling.....	8
1.08	Safety Requirements	8

PART 2 – PRODUCTS

2.01	Polyurethane Foam	8
2.02	Protective Coating System	9
2.03	Related Products	10

PART 3 – EXECUTION

3.01	Application of Products	10
3.02	Substrate Consideration and Preparation	10
3.03	Primer Application.....	11
3.04	Spray Polyurethane Foam Application	11
3.05	Protective Coating Application.....	11
3.06	Vapor Retarder Application	12
3.07	Thermal Barrier Application	12

ILLUSTRATIONS

Detail 1 – Vapor Drive Toward Inside SPF Applied to Exterior	13
Detail 2 – Vapor Drive Toward Inside SPF Applied on Interior	14
Detail 3 – Vapor Drive Toward Exterior SPF Applied to Exterior	15
Detail 4 – Vapor Drive Toward Exterior SPF Applied to Interior	16

OTHER PROGRAMS AND SERVICES OFFERED BY SPFA

Professional Training	17
Technical Documents	17
Association Newsletter.....	17
SPFA Website	17
Hot Line 800 Number	17

TABLE OF CONTENTS

DESIGN CONSIDERATIONS

GENERAL CONSIDERATIONS

Spray-applied polyurethane foam can provide an excellent insulating and/or weatherproofing augmentation to metal buildings. Polyurethane foam forms an integral bond with the metal building surface conforming to irregular surface profiles and providing an effective air seal. Spray polyurethane foam (SPF) may be applied to metal building exteriors or interiors. When applied to exterior surfaces, the SPF must be covered with an elastomeric coating for weather protection. When applied to interior surfaces, the SPF must be covered with a 15-minute thermal barrier for fire protection. Vapor retarders may be required depending on the particulars of the project.

The performance of a spray-applied polyurethane foam insulation system depends on the performance of all the component parts as well as ambient conditions within and without the building. Therefore, specifiers should consult with the respective material suppliers and the contractor to receive written confirmation of their agreement to all facets of the insulation system. This should include, but not be limited to, material selection, expansion joints, load design, vapor retarders, thermal barriers, and flashing details.

Spray polyurethane foam can successfully be applied to most metal building surfaces and components. However, the following general practices must be observed.

DETERMINING INSULATION THICKNESS

The following method should be considered when determining insulation thickness:

1. Building and Energy Codes: Most code agencies require certain buildings to meet the energy conservation standards prescribed by the Council of American Building Officials (CABO) Model Energy Code.
2. Condensation Control: Condensation can occur inside a building when interior surface temperature is lower than the dew point of the inside air. Insulation thickness to control this condensation must be based on the design dew point and the design exterior ambient temperature.
3. Economic Thickness: Greater insulation thickness decreases heat and cooling costs and the cost of HVAC equipment. However, there is a diminishing return to adding thickness where the time-weighted cost of additional insulation exceeds the expected energy savings. The economic thickness calculation determines the

added incremental insulation thickness, which meets a specified return on investment from energy cost savings.

4. Minimum Practical Thickness: Spray polyurethane foam applications must be sprayed to a minimum thickness to conform to the substrate and to achieve proper foam cure. For most relatively smooth substrates the minimum practical thickness is one inch but for corrugated or unusual substrate configurations may require greater thickness to achieve a suitable finished foam surface.

The best method to determine insulation thickness would be to determine the minimums for each of the situations described above and choosing the method, which prescribes the greatest insulation thickness.

SURFACE PREPARATION

1. Metal building components must be secured against movement prior to the application of the SPF system.
2. Prior to application of primer, vapor retarder or SPF, the surface must be dry, free of loose dirt or any contaminants that may interfere with adhesion of any of the respective components.
3. Contaminants may be removed by use of pressure washing, steam cleaning, vacuum equipment, hand power broom, chemical solvents, grit blasting, manual scraping, etc.

SELECTION OF PRIMER

If a primer is required, select it based on the type substrate to be sprayed; the building's intended use, and the recommendations of the SPF and primer manufacturers.

SELECTION OF A VAPOR RETARDER

The need and location of a vapor retarder are based on the following factors:

1. Direction and degree of the vapor drive
 - a. Interior design temperature
 - b. Interior design humidity
 - c. Exterior design temperature
 - d. Exterior design humidity

DESIGN CONSIDERATIONS

2. Location of the intended spray polyurethane foam (SPF) application
 - a. Interior wall/ceiling surface
 - b. Exterior wall/roof surface.

For example, if the metal buildings intended use is as a cooler, a vapor retarder will likely be required if the SPF is applied to the building's exterior surface (the warm side of the building). Conversely, if the building site is in a cool climate and the building will be heated, a vapor retarder will likely be required if the spray foam is applied to the building's interior surface.

See SPFA Publication *Moisture Vapor Transmission*, Stock Number AY-118.

If a vapor retarder is required, its selection should be based on the following criteria:

1. Perm rating required (based on moisture vapor drive and perm ratings of other components).
2. Compatibility with adjoining materials.
3. Manufacturer's recommendation.

SELECTION OF THE SPRAY POLYURETHANE FOAM SYSTEM

Spray-applied polyurethane foam is the product of reaction of two chemical components. When sprayed on a substrate a seamless layer forms. Thickness can be varied to meet insulation requirements. The contractor, in the case of SPF applications, fabricates the product on site in accordance with the manufacturer's instructions.

A wide range of SPF systems are available in various densities, each exhibiting different temperature limitations, combustibility characteristics, etc. The use of these systems, in combination with each other or with other insulation products, offers a wide range of economical installations. Consult with the contractor and the polyurethane foam manufacturer to determine which system best suits the project.

From a fire safety standpoint, spray polyurethane foam (SPF) can be used safely. It is important, however, that all persons associated with the design, fabrication, storage, and installation understand the materials and environments involved.

Polyurethane foam insulation is combustible and should be treated as such. Flame spread ratings provided for polyurethane products using small scale tests are not intended to reflect the hazards presented by this or any other materials under actual fire

conditions. Care must be taken to insure that the foam is not exposed to temperatures in excess of 200° F.

Prohibit open flames, cutting and welding torches, electric heaters, high intensity lamps, and smoking materials from foam storage and installation areas. If hot work must be done near exposed polyurethane foam, shield the foam from heat and sparks by a temporary thermal barrier such as sheet rock and post a fire watch. Do not weld or cut metal which is in contact with polyurethane foam.

SELECTION OF A PROTECTIVE COATING SYSTEM

When the SPF is applied to the exterior of a metal building, the foam must be covered with a protective elastomeric coating system. The coating system protects the foam from deterioration due to the sun's ultra-violet rays and other weather related phenomena. The coating must bond to the foam to become an integral part of the insulation system.

Coating systems designed for use over foam cure to form a water-resistant protective membrane. The dry film thickness (DFT) of the protective coating shall be in compliance with the coating manufacturer's specification.

Consider the following items in the selection of the coating system:

1. Physical Characteristics
 - a. Chemical resistance.
 - b. Water vapor permeance.
 - c. Tensile and elongation properties.
 - d. Retention of physical properties upon aging.
 - e. UV resistance.
2. Performance Characteristics
 - a. Environment in which it is to be used (abrasion and impact).
 - b. Life expectancy
 - c. Ease of maintenance.
 - d. History of similar applications or laboratory data relating to the application in question.
 - e. Adhesion to the polyurethane foam.
 - f. Combustibility characteristics, individually and in combination with the selected polyurethane foam systems.
 - g. Aesthetic qualities.

For additional information on protective coating systems, see SPFA Publication *A Guide for Selection of Protective Coatings Over Sprayed Polyurethane Foam*,

DESIGN CONSIDERATIONS

Stock Number AY-102.

SELECTION OF A THERMAL BARRIER

When polyurethane foam is spray applied to interior surfaces, it **must** be protected by a 15-minute thermal barrier. Various types of thermal barriers are available which may be sprayed, troweled, or mechanically fastened to the foam. For additional information on thermal barriers, see SPFA Publication *Thermal Barriers for the Spray Polyurethane Foam Industry*, Stock Number AY-126.

Consider the following in the selection of a thermal barrier:

1. Building code requirements.
2. Adhesion to the SPF.
3. Environment in which it is to be used.
4. Aesthetic qualities.
5. Ease of maintenance.

DESIGN CONSIDERATIONS

METAL BUILDING DECISION FLOW CHART

Figure 1 provides a decision flow chart to determine under what circumstances protective coatings, vapor retarders, or thermal barriers are likely to be required.

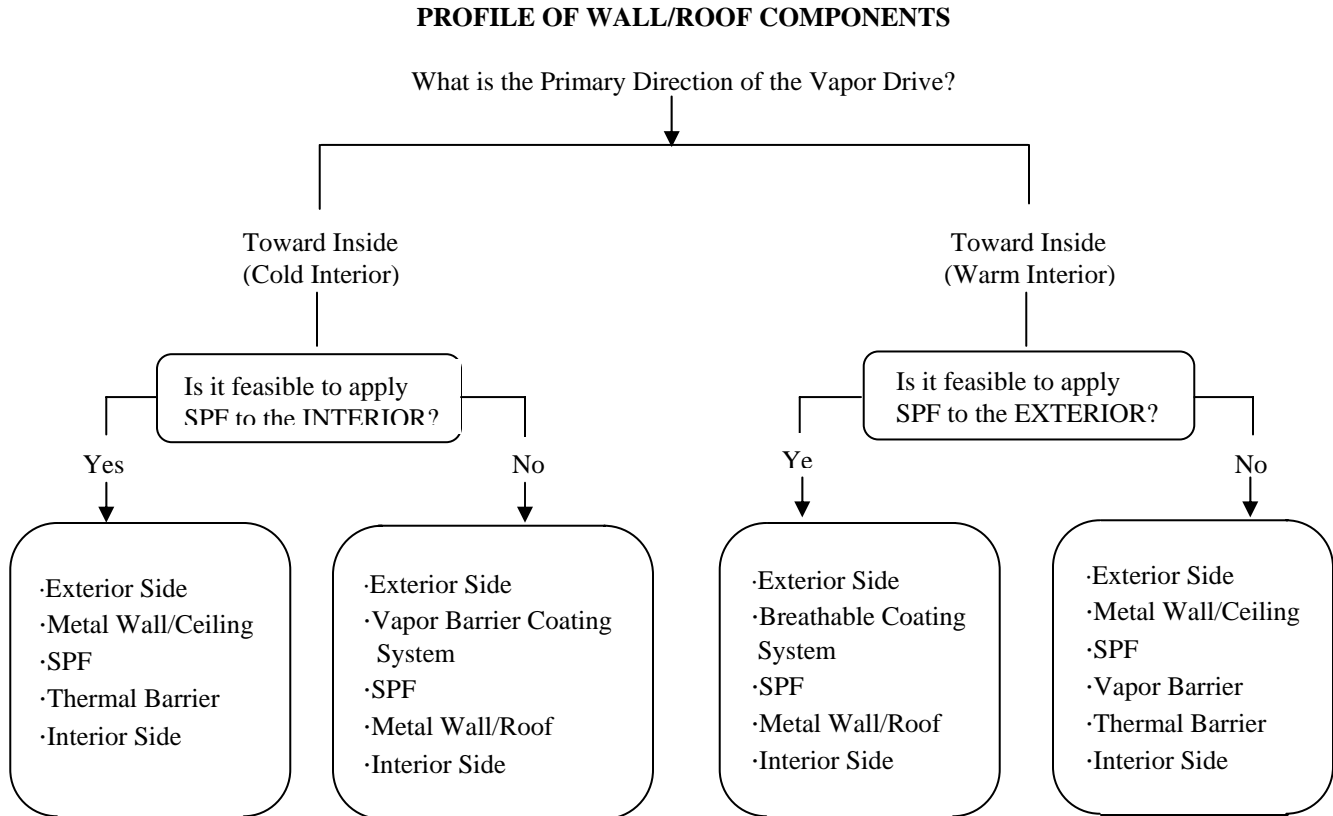

Figure 1: Metal Building Decision Flow Chart. Use this chart as a guide to determine when protective coating systems, vapor retarders, and thermal barriers are likely to be required.

RECOMMENDED GUIDE SPECIFICATION FOR INSULATING METAL BUILDINGS

PART 1 - GENERAL

This guide discusses the application of seamless sprayed-in-place polyurethane foam (SPF) for use as a metal building insulation system. Your contractor, selected systems manufacturer, and local code agencies can assist you, as each project must be assessed individually.

1.01 SCOPE OF WORK

Furnish all labor, materials, tools and equipment necessary for the application of a SPF metal building insulation system, including accessory items, subject to the general provisions of the contract.

1.02 RELATED WORK SPECIFIED ELSEWHERE

A. Rough Carpentry	Section 06100
B. Insulation, Other	Section 07200
C. Thermal Barrier	Section 07220
D. Vapor Retarder	Section 06100
E. Mechanical	Division 15
F. Electrical	Division 16

1.03 QUALITY ASSURANCE

Contractor Qualifications: The contractor should provide information concerning projects similar in nature to the one proposed, including location and person to be contacted. Some manufacturers of sprayed polyurethane foam systems have approval programs and/or licensing methods that could be required.

1.04 SUBMITTALS

- A. Manufacturer's published data sheets or letter of certification that their products comply with the materials specified. This is to include SPF and, if required, coatings, primers, thermal barriers, and vapor retarders.
- B. Shop drawings on sheet metal, accessories, or other fabricated items, if required.
- C. Manufacturer's application or installation instructions.
- D. Contractor/applicator certification from SPF supplier and/or coating and thermal barrier manufacturers and references. See Section 1.03.
- E. Approval and information guides for applicable local or national building codes.
- F. Safety and handling instructions for storage, handling and use of the materials to include Material Safety Data Sheets (MSDS).
- G. Field quality control procedures to be utilized by the contractor/applicator to insure proper preparation and installation of SPF, coating, and thermal barriers, detail work and follow-up inspection.

1.05 MATERIALS DELIVERY AND STORAGE

- A. Materials shall be delivered in the manufacturers original, tightly sealed containers or unopened packages, all clearly labeled with the manufacturer's name, product identification, safety information, and batch or lot numbers where appropriate. Where materials are covered by a referenced specification, the labels shall bear the specification number, type and class, as applicable.
- B. Containers shall be stored out of the weather and direct sun, where the temperatures are within the limits specified by the manufacturer.
- C. All materials shall be stored in compliance with local fire and safety requirements.

RECOMMENDED GUIDE SPECIFICATION FOR INSULATING METAL BUILDINGS

1.06 ENVIRONMENTAL CONDITIONS

- A. Do not apply the SPF below the temperature and/or above humidity specified by the manufacturer for ambient air or substrate. If foam is being applied to the metal building's exterior, do not apply during inclement weather.
- B. Do not apply protective coatings when there is ice, frost, surface moisture, or dampness present on the surface to be coated. Prior to applying the coatings, check the polyurethane foam to insure the surface is dry. Apply protective coatings in accordance with the coating manufacturer's application instructions.
- C. If required, apply thermal barriers and vapor retarders in accordance with the manufacturer's application instructions.

1.07 SEQUENCE AND SCHEDULING

In new construction projects the SPF is installed when the preparation of the metal building wall/roof are in place and in coordination with other building trades.

1.08 SAFETY REQUIREMENTS

- A. See API Bulletin *MDI-Based Polyurethane Foam Systems: Guidelines for Safe Handling and Disposal*, Stock Number AX-119.
- B. Refer to appropriate Material Safety Data Sheets (MSDS) for additional safety information.
- C. Before starting to apply spray polyurethane foam or coating, all HVAC equipment on the roof must be turned off. These units and any other potential sources of air entry into the building must be sealed.
- D. Proper disposal of waste materials and containers must be done in compliance with the manufacturer's guidelines and/or federal, state, and local regulatory agencies.
- E. For protection against exposure to higher levels of MDI (greater than 1 ppm) or for entry into confined spaces, workers must wear either a self-contained breathing apparatus, with full face piece, operated in a pressure-demand or other positive-pressure mode, or a combination respirator, including a Type C air-supplied respirator, with full face piece, operated in a pressure-demand or other positive-pressure mode, and an auxiliary self-contained breathing apparatus, operated in a pressure-demand or other positive-pressure mode. See API Bulletin *MDI-Based Polyurethane Foam Systems: Guidelines for Safe Handling and Disposal*, Stock Number AX-119.
- F. Personal protective clothing should be worn. This includes the wearing of the appropriate protective clothing, including eye protection (face shield or chemical worker's goggles), gloves and coveralls. This is essential to preventing skin exposure and is strongly recommended for most individuals who work with PMDI.

PART 2 - PRODUCTS

2.01 POLYURETHANE FOAM

- A. The polyurethane foam to be applied shall be a two component system made by combining an isocyanate (A) component with a polyol (B) component and shall possess the following physical characteristics (use the appropriate table):

RECOMMENDED GUIDE SPECIFICATION FOR INSULATING METAL BUILDINGS

INTERIOR POLYURETHANE FOAM: CLOSED CELL TYPE

<u>PROPERTIES</u>	<u>ASTM TEST</u>	<u>VALUE</u>	<u>UNITS</u>
Density (sprayed-in-place)	D-1622	24 - 48 (1.5 - 3.0)	kg/m ³ (lbs/ft ³)
Compressive Strength	D-1621	100 (15) (Minimum)	kPa (lb/in ²)
R-Value		1.1 (6.2) aged	K·m ² /W (°F·ft ² ·hr/Btu)
Closed Cell Content	D-2856	90% (Minimum)	% Value
Flammability *	E-84	<75	
Smoke *	E-84	<450	

INTERIOR POLYURETHANE FOAM: OPEN CELL TYPE

<u>PROPERTIES</u>	<u>ASTM TEST</u>	<u>VALUE</u>	<u>UNITS</u>
Density (sprayed-in-place)	D-1622	6 - 10 (0.4 - 0.6)	kg/m ³ (lbs/ft ³)
R-Value		0.60 (3.4) aged	K·m ² /W (°F·ft ² ·hr/Btu)
Flammability *	E-84	<75	
Smoke *	E-84	<450	

RECOMMENDED GUIDE SPECIFICATION FOR INSULATING METAL BUILDINGS

EXTERIOR POLYURETHANE FOAM

<u>PROPERTIES</u>	<u>ASTM TEST</u>	<u>VALUE</u>	<u>UNITS</u>
Density (sprayed-in-place)	D-1622	40 - 50 (2.5 - 3.0)	kg/m ³ (lbs/ft ³)
Compressive Strength	D-1621	280 (40) (Minimum)	kPa (lb/in ²)
Closed Cell content	D-2856	90% (Minimum)	% Value
R-Value		1.1 (6.2) Aged	K·m ² /W (°F·ft ² ·hr/Btu)
Flammability *	E-84	<75	
Smoke *	E-84	<450	

***This standard is used solely to measure and describe properties of products in response to heat and flame under controlled laboratory conditions. This numerical flame spread rating is not intended to reflect hazards presented by this or any other material under actual fire conditions.**

- B. Polyurethane Foam Primers: Primers used shall be as recommended by the manufacturer of the SPF materials specified.
- C. Fire Safety Requirements: See API Publication *MDI-Based Polyurethane Foam Systems: Guidelines for Safe Handling and Disposal*, Stock Number AX-119.

2.02 PROTECTIVE COATING SYSTEM

- A. The elastomeric coating system may be one or more of the following types:
 1. Acrylic
 2. Butyl Rubber
 3. Hypalon
 4. Neoprene
 5. Silicone
 6. Polyurethane Elastomer
 7. Modified Asphalt
- B. Physical Properties: The elastomeric coating system shall possess the following physical characteristics (NOTE: Specifier shall list physical properties of selected elastomeric coating system):

RECOMMENDED GUIDE SPECIFICATION FOR INSULATING METAL BUILDINGS

<u>PROPERTIES</u>	<u>ASTM TEST</u>	<u>VALUE</u>
Tensile Strength	D-412	
Elongation	D-412	
Hardness Shore A	D-2240	
Tear Resistance	D-624	
Light Exposure and Weathering	G-151/154	
Moisture Vapor Transmission	E-96 Procedure E	
Chemical Resistance	D-1308	

- C. General: It is recommended that the coating system be elastomeric in nature (at least 100% elongation). Within these generic-coating types are both vapor retardant and breathable systems.

2.03 RELATED PRODUCTS

- A. 15-Minute Rated Thermal Barriers.
1. Sprayed-in-place cementitious.
 2. Sprayed-in-place fiber.
 3. Minimum 13 mm (½-inch) gypsum board.
 4. Other.
- B. Vapor Retarder - That which is rated at or less than 3 ng/m²·s·Pa (0.05 perm) ASTM E-96, Method E.
1. Modified asphalt.
 2. Butyl rubber.
 3. Polyethylene film.
 4. Other.
- C. Substrate Primers (if required) - The primer to be applied must be specifically selected for the given substrate to be primed and must be compatible with the SPF.

PART 3 - EXECUTION

3.01 APPLICATION OF PRODUCTS

The products intended for use in metal building insulation systems must be applied within the manufacturer's guidelines for temperature, humidity, and other atmospheric conditions. In addition, they must be sequenced so as to take into consideration substrate preparation, proper cure times, and inter-coat adhesion.

3.02 SUBSTRATE CONSIDERATION AND PREPARATION

Surface preparation for metal buildings is outlined below:

- A. Primed: If the primed metal surface is free of loose scale, rust, weathered or chalking paint it can be cleaned using pressure washing, steam cleaning, solvent cleaning, vacuum equipment and hand or power tools to remove loose dirt, grease, oil, or other contaminants.
- B. Non-Ferrous Metals (including galvanized and stainless steel): When required, clean surfaces as recommended by the primer manufacturer.
- C. Unpainted Steel: Clean as recommended by primer manufacturer in order to prepare the steel surface for the primer.

RECOMMENDED GUIDE SPECIFICATION FOR INSULATING METAL BUILDINGS

3.03 PRIMER APPLICATION

When required, the primer shall be applied to the properly prepared substrate and allowed to cure in accordance with the manufacturer's guidelines.

3.04 SPRAY POLYURETHANE FOAM APPLICATION

- A. The spray polyurethane foam components (A) and (B) shall be processed in accordance with the manufacturer's instructions.
- B. The polyurethane foam shall be sprayed within the manufacturer's guidelines for temperature, humidity, and other atmospheric conditions. Take precautions to protect surroundings from overspray.
- C. The polyurethane foam shall be sprayed in minimum 13 mm (½ inch) thick passes (lifts) with the overall thickness to be a minimum of ____ mm (inches). The full thickness of SPF to be applied within any given area should be completed in one day.
- D. The final sprayed polyurethane foam surface shall be "smooth, orange peel, coarse orange peel, or verge of popcorn." Polyurethane foam surfaces termed "popcorn" or "treebark" are not acceptable and should be corrected. See SPFA Publication *Spray Polyurethane Foam Systems for New and Remedial Roofing* for foam texture photographs, Stock Number AY-104.
- E. Any damage or defects to the polyurethane foam shall be repaired prior to applying protective coatings, vapor retarders, or thermal barriers.
- F. The polyurethane foam surface shall be free of contaminants that will impair adhesion of the protective coatings, vapor retarders, or thermal barriers.

3.05 PROTECTIVE COATING APPLICATION

- A. Inspection

Prior to the application of the protective coatings, the polyurethane foam shall be inspected to insure that conditions required by Section 3.04 have been met.
- B. The coating application shall not proceed during inclement weather. The applicator shall apply the protective coating within the temperature and humidity ranges specified by the manufacturer for ambient air and substrate. Wind barriers should be used if wind conditions could affect the quality of the installation.
- C. Application
 1. Base Coat
 - a. The base coat shall be applied the same day as the polyurethane foam when possible. If more than 24 hours elapse prior to the application of the base coat, the polyurethane foam shall be inspected for UV degradation, oxidation, and contaminants. The manufacturer's recommendations shall be followed to prepare the foam surface before coating applications.
 - b. The base coat shall be applied at a uniform thickness with the rate of application governed by the polyurethane foam surface texture. Coatings shall be applied at a rate to achieve the minimum dry film thickness (DFT) specified by the protective coating manufacturer.
 - c. The coating shall be allowed to cure and be inspected for pinholes, thinly coated areas, uncured areas, and other defects. Defects shall be corrected.
 2. Top Coat and/or Subsequent Coat
 - a. Inspect the base coating for defects and thin coating. Correct defects.
 - b. Subsequent coating should be applied in a timely manner to insure proper adhesion between coats.
 - c. Final coat shall be inspected for defects and thin coating. Correct defects in accordance with manufacturer's recommendations.
- D. Coating will be reinforced in accordance with manufacturer's instructions around protrusions, walkways, etc.

RECOMMENDED GUIDE SPECIFICATION FOR INSULATING METAL BUILDINGS

3.06 VAPOR RETARDER APPLICATION

- A. When required, a vapor retarder shall be applied to the substrate to be insulated or to the finished SPF insulation. The predominant direction of the vapor drive and the placement of the spray foam insulation (interior or exterior) determines whether or not a vapor retarder is required over the SPF. (Refer to Figure 1.)
- B. The vapor retarder shall be applied in accordance with manufacturer's specifications so as to achieve the desired perm rating per ASTM E-96, Method E.

3.07 THERMAL BARRIER APPLICATION

When the spray polyurethane foam is applied to the interior surface of a metal building, it must be covered with a 15-minute rated thermal barrier. The thermal barrier must be applied in accordance with manufacturer's guidelines.

RECOMMENDED DETAILS FOR INSULATING METAL BUILDINGS

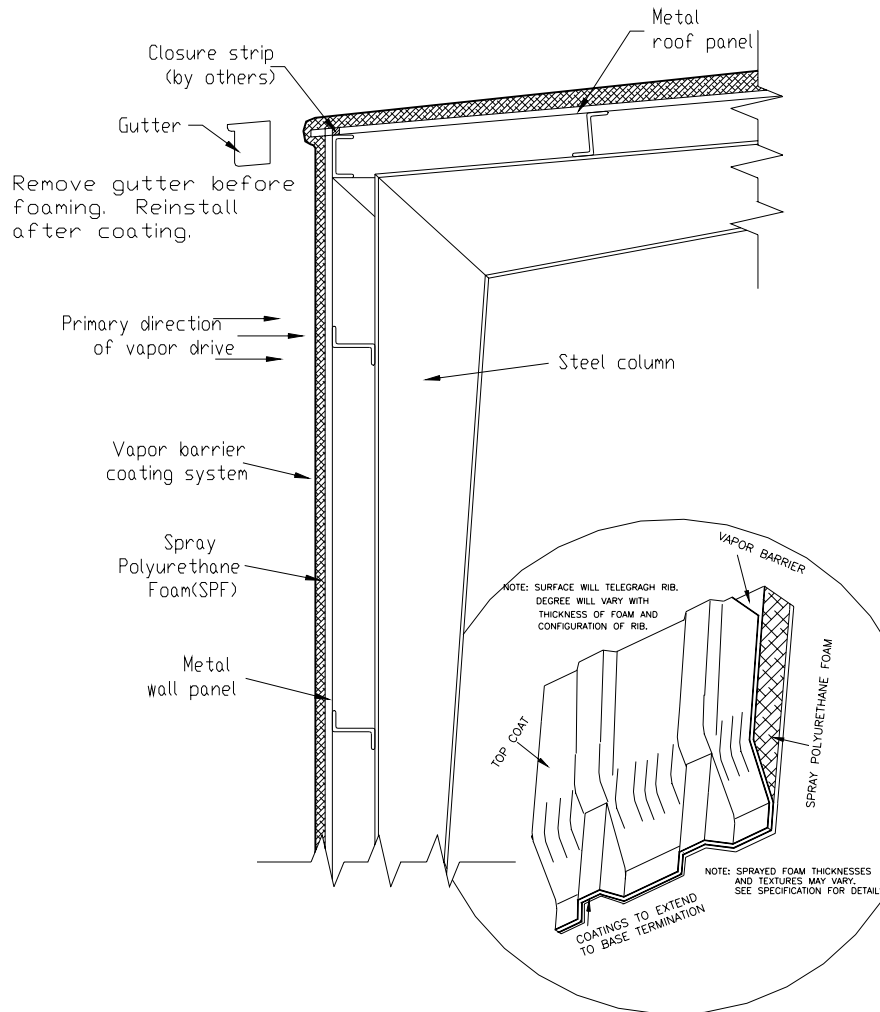

Base Termination

VAPOR DRIVE TOWARD INSIDE SPF APPLIED TO EXTERIOR

RECOMMENDED DETAILS FOR INSULATING METAL BUILDINGS

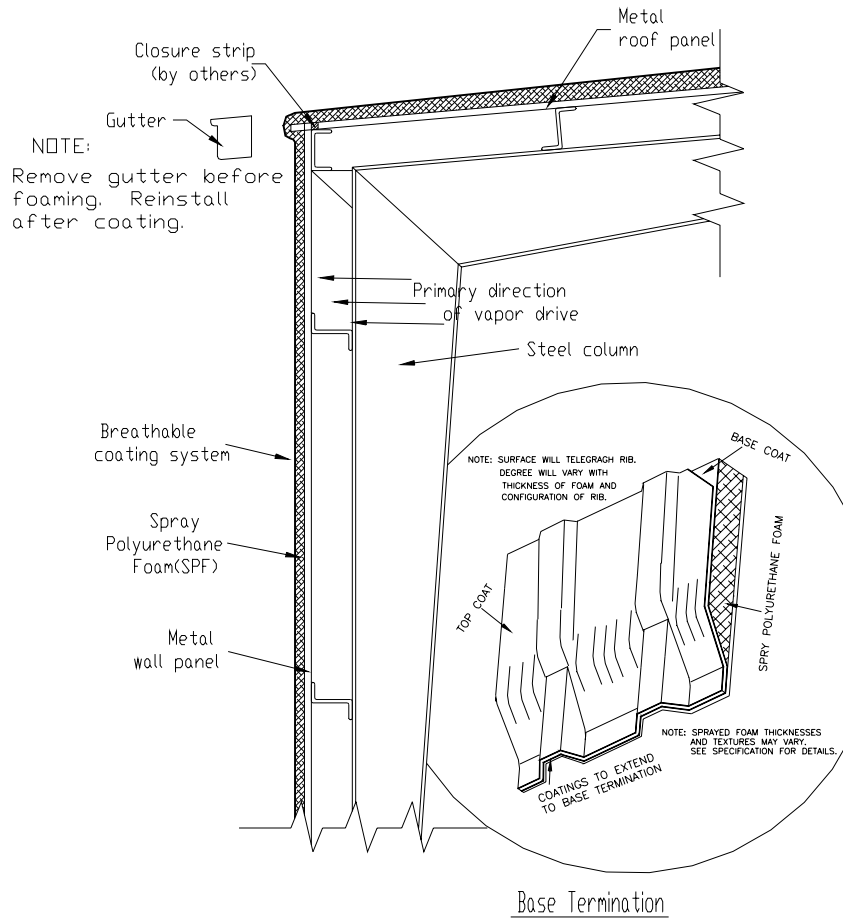

VAPOR DRIVE TOWARD EXTERIOR SPF APPLIED TO EXTERIOR

RECOMMENDED DETAILS FOR INSULATING METAL BUILDINGS

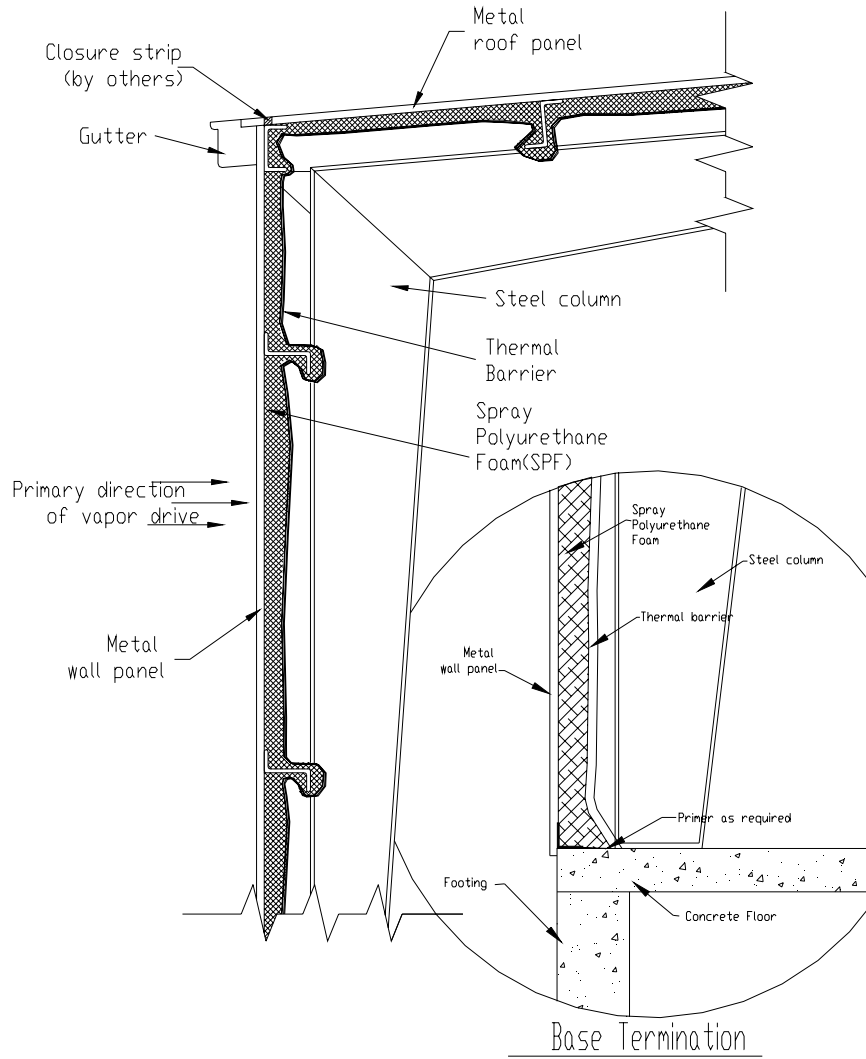

VAPOR DRIVE TOWARD INSIDE SPF APPLIED ON INTERIOR

RECOMMENDED DETAILS FOR INSULATING METAL BUILDINGS

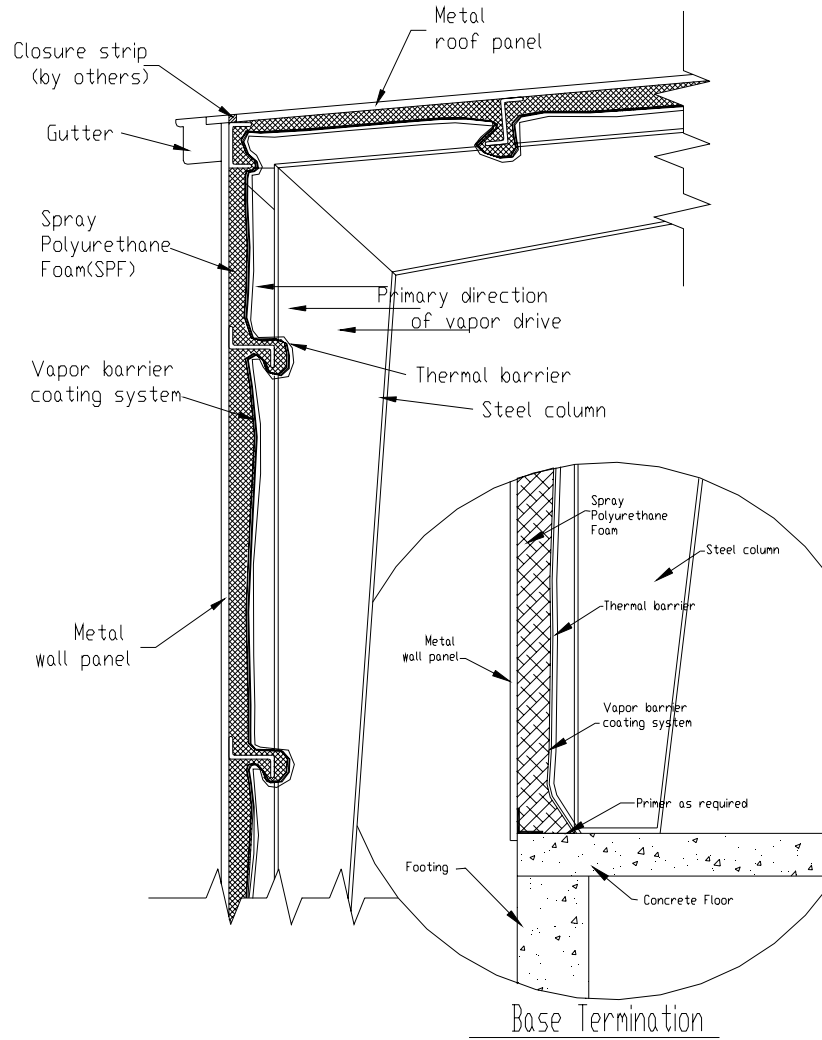

VAPOR DRIVE TOWARD OUTSIDE SPF APPLIED ON INTERIOR

OTHER PROGRAMS AND SERVICES OFFERED BY SPFA

Professional Training

The Accreditation Program offers individual and company accreditation in five areas: Contractor, Distributor, Elastomeric Coating Supplier, Foam Supplier and Independent Inspector. The objectives of the program are to **PROVIDE** an established set of criteria; to **IDENTIFY AND RECOGNIZE** individuals and companies; and to **ENCOURAGE** responsibility for the quality of their work through self-education.

Technical Documents

- AY-102 A Guide for Selection of Protective Coatings Over Spray Polyurethane Foam Roofing Systems
- AY-103 Spray Polyurethane Foam Insulation Systems for Metal Service Vessels Operating Between -30°F and 200°F
- AY-104 Spray Polyurethane Foam Systems for New and Remedial Roofing
- AY-107 Spray Polyurethane Foam Blisters – Their Causes, Types, Prevention and Repair
- AY-110 Spray Polyurethane Foam Aggregate Systems for New and Remedial Roofing
- AY-111 Spray Polyurethane Foam Systems for Cold Storage Facilities Operating Between -40°F and 50°F
- AY-112 Spray Polyurethane Foam for Building Envelope Insulation and Air Seal
- AY-113 Contractor/Applicator Handbook
- AY-116 Spray Applied Polyurethane Foam and Elastomeric Coating Systems (10 min. VHS Video)
- AY-117 Spray Applied Polyurethane Foam and Aggregate Roof Systems (10 min. VHS Video)
- AY-118 Moisture Vapor Transmission
- AY-119 Glossary of Terms Common to the Spray Polyurethane Foam Industry
- AY-121 Spray Polyurethane Foam Estimating Reference Guide
- AY-122 The Renewal of Spray Polyurethane Foam and Coating Roof Systems
- AY-124 Wind Uplift Brochure
- AY-125 P-Rating Brochure
- AY-126 Thermal Barriers for Spray Polyurethane Foam Industry
- AY-127 Maintenance Manual for Spray Polyurethane Foam Roof Systems
- AY-129 SPF Roofing “Seamless Roofing & Insulation” 8 Page Color Brochure
- AY-130 SPF Roofing “Sustainable Roofing” 4 Page Color Brochure
- AY-131 Whole Wall Rating/Label for Metal Stud Wall Systems with SPF; Steady State Thermal Analysis
- AY-132 The SPF Roofing Systems – 11.5 min. Informative Video offers a comprehensive pictorial review of this most extraordinary roofing concept.
- AY-133 Maintenance Manual for Spray Polyurethane Foam Roof Systems – **Spanish Version**
- AY-134 Guideline for Insulating Metal Buildings with Spray Polyurethane Foam
- AX-171 Course 101-R Chapter 1: Health, Safety and Environmental Aspects of Spray Polyurethane Foam and Coverings. Video and Text

Association Newsletter published quarterly with a “Special Show Edition” for the annual conference offers articles, alerts, and technical information affecting the industry.

The SPFA Web Site is a direct communication to all member suppliers and contractors with web access. Up to date information is offered.... And as a member, you may link into the web site (www.sprayfoam.org)

A **“HOT-LINE” 800 number** is available for your use to answer those technical questions (800-523-6154). The SPFA sponsors research and development and product testing that allows approval for generic types of spray foams, coverings, and related products.